

DISTRIBUTOR/AGENT:	DATE OF ORDER:
	DATE OF DELIVERY:
	NAME OF THE ADDRESSEE/USER:



Product marked **CE**

F E A T U R E S

- **Ergonomic and modular tricycle** that helps the user to keep a proper posture and makes the ride easier thanks to its design and components.
- **Lowered frame** for easy ascent and descent.
- **Front positioned bottom bracket** for easier pedaling.
- **Optimized pinion** to facilitate the pedaling in safety.
- **Folding frame** to save space during transport.
- **Adjustable handlebar** in height, backward-forward and reversible.
- **Wide and ergonomic handles**, to increase comfort.
- **Bell.**
- **Front and back lamp.**
- **Front brake with locking device** (available from size M) for ascent and descent, that can be operated by the lever either on the right or on the left side of the handlebar. The distance between the brake lever and the handlebar is adjustable by screw.
- **Adjustable ergonomic saddle** in height, tilt and backward-forward
- **Rear storage basket.**
- **16" pneus wheels** run on ball bearings. A mechanism on the rear wheels allows easy adjustment of the tension of the chain.
- **Quick release front wheel.**



Attention!
Read carefully the user and maintenance manual

Please check off the interested products: _____

M E A S U R E S

FRAME COLOUR:

- Blue
- Red
- Green

Storage basket
Internal measures

View from above

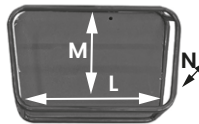

L	49,7 cm	In 19,5
M	27,4 cm	In 10,7
N	9,6 cm	In 3,6
Max. Load	25 kg	lb 55

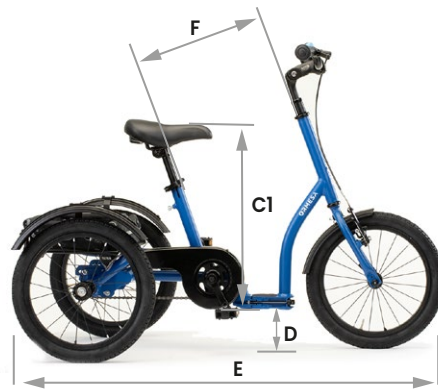

C1= C2-2cm

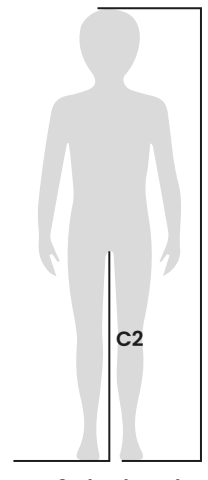

C2= leg length

	Max. Load	Aid Weight	A	B	C1*	D	E	F	G	I	User Height (H)
Medium	kg. 60 lb 132,2	kg. 23 lb. 50,7	cm 55 in 21,6	cm 75 in 29,5	cm 59-72 in 23,2-28,3	cm 16 in 6,3	cm 136 in 53,5	cm 45 in 17,7	cm 81 in 31,8	cm 90 in 35,4	cm 120-145 in 47,2-57

*With standard saddle. You can further adjust the height of the saddle (± 3cm) acting on the clamp.



download and send the form to info@ormesa.com

Foligno (PG) Italy • Tel. +39 0742 22927 • Fax +39 0742 22637 • www.ormesa.com

Choose the configuration →

Fixed Pinion

Free Wheel

Differential and Fixed Pinion

Differential and Free Wheel

Three-speed transmission with differential. Allows braking by counter-pedaling, shifting when the tricycle is stationary, and reversing.

OPTIONAL COMPONENTS, ONLY CHOOSABLE WHEN ORDERING THE TRICYCLE

864 Disc brake. only for models with differential and without gearbox.



Standard handlebar

S M
 Left Right

Please choose the position of the brake. In the absence of indications, the brake will be mounted on the right.



847 Cranks adjustable in length decreases the distance between saddle and pedal of 3,5 cm.



OPTIONAL COMPONENTS, ALSO CHOOSABLE SEPARATELY

880 Ergonomic handles adjustable in inclination independently (1 pair). Same size as the Handlebar.

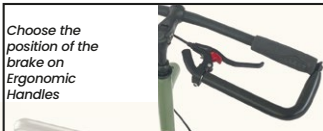

845 Forearm support

Left Right
 mini S-M



875 Wrist retainer with support and multi-adjustable glove independently.

Left Right
 mini S-M



842P Pelvic support with belt, adjustable in height.

Also select the component 883

mini-S
 M



842T Trunk support, adjustable in height, inclination and backward-forward with belt and joint. Also select the component 883

mini-S
 M



883 Rod adjustable in height for Thoracic/Pelvic support (single rod). Please select even the type of support.



877 Flat backrest



843 Abductive saddle with holder for supports



840 Pedal cages with straps (1 pair).



841 Pedal cage with length and width adjustable foot imprints and fastening straps, with support kit.

Left Right
 mini-S M-L-XL



846 Ankle support adjustable in height, with support kit. Only with component 841.

Left Right
 S-M L-XL

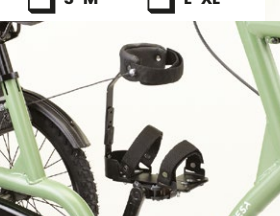

923 Additional assistant handle.



963 Steering assistant handle adjustable in height.



881 steering limiter.



882 steering limiter with springs to return the steering to the straight position.



879 Front basket.



878 878 MTB tires (3 pcs.) in alternative to standard tyres



COMPONENTS MEASURES

842P

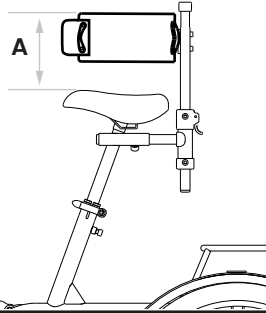

A	
mini/S	8,5-14 cm/in 3,3-5,5
M	8,5-21 cm/in 3,3-8,3
L/XL	8,5-23 cm/in 3,3-9

842T

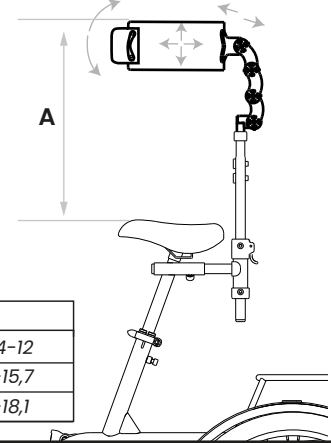

A	
mini/S	19-30,5 cm/in 7,4-12
M	19-40 cm/in 7,4-15,7
L/XL	19-46 cm/in 7,4-18,1

842P - 842T

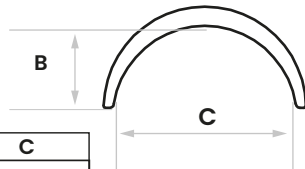

	B	C
mini/S	10,5 cm/in 4,1	23 cm/in 9
M	14,5 cm/in 5,7	31 cm/in 12,2
L/XL	17,5 cm/in 6,8	35 cm/in 13,7

843

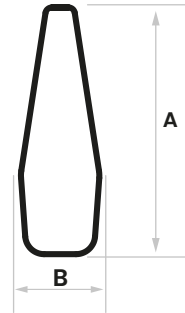

	A	B
mini/S	31 cm/in 12,2	12,5 cm/in 4,9
M/L/XL	40 cm/in 15,7	14 cm/in 5,5

841

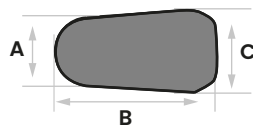

841 foot imprint size			
	A	B	C
mini/S	from 5 to 7 cm from 1,9 to 2,7 in	from 12,5 to 16,5 cm from 4,9 to 6,5 in	from 6 to 7 cm from 2,3 to 2,7 in
M/L/XL	from 8,2 to 9,4 cm from 3,2 to 3,7 in	from 20 to 22,5 cm from 7,8 to 8,8 in	from 10,4 to 12 cm from 4 to 4,7 in

Standard handlebar

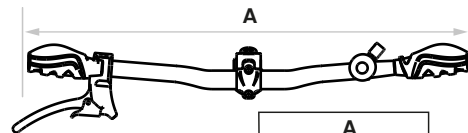

	A
mini	45 cm / in 17,7
S	50 cm / in 19,6
M	55 cm / in 21,6
L	60 cm / in 23,6
XL	64 cm / in 25,2

Notes:
