

Standy Electro WING

INGLESE - COD. 22738 - 10-12-10

Authorized Dealer

Standy Electro WING

M E A S U R E S

HYPHEN-SEPARATED NUMBERS INDICATE THE MINIMUM AND MAXIMUM RANGE OF ADJUSTMENT

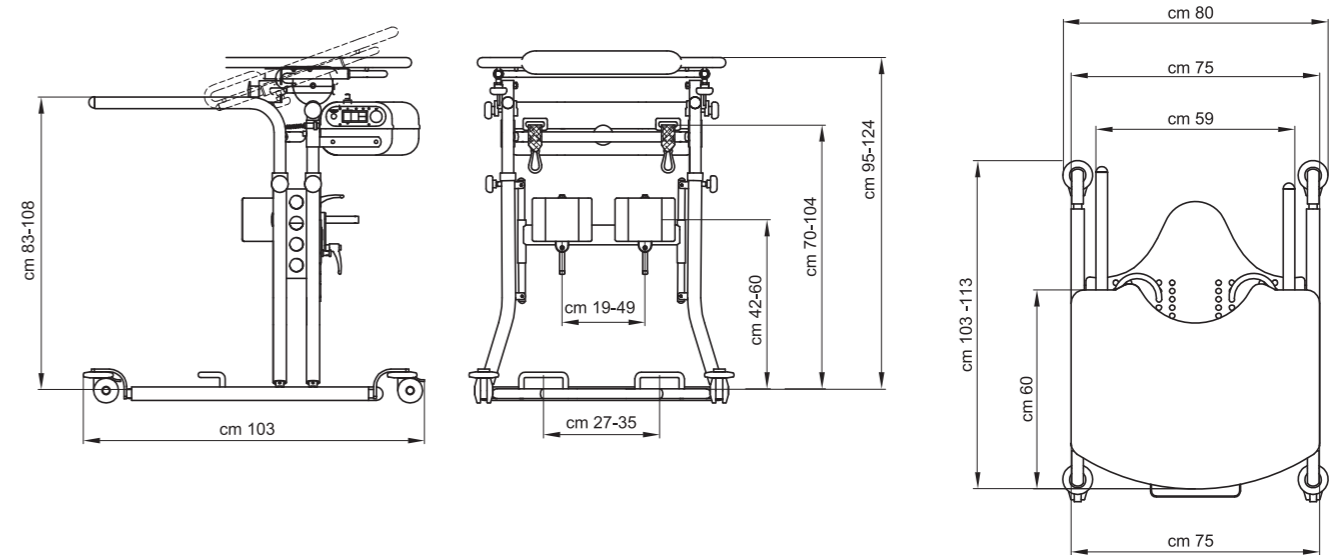

STANDARD LIFTING BAND

908 STANDARD LIFTING BAND WITH PELVIS BELT

907 MAXI LIFTING BAND

909 MAXI LIFTING BAND WITH PELVIS BELT

WEIGHT OF THE AID Kg 62

MAX. LOAD Kg 120

The copyright even if partial is not allowed without the authorization of the manufacturer. The manufacturer reserves the right to make changes without any notice.



design and quality
MADE IN ITALY since 1980



ORMESA S.r.l. - Via A. Da Sangallo, 1 - PACIANA
06034 FOLIGNO (PG) ITALY - TEL. +39 0742 22927 (r.a.) FAX +39 0742 22637
E-mail: info@ormesa.com - www.ormesa.com

COMPANY WITH QUALITY MANAGEMENT
SYSTEM CERTIFIED BY DNV
= ISO 9001:2008 =



functions



We recommend to wear tight trousers to achieve the optimal grip of the band



accessories

902
Front foot restraints
with belts



867
pelvis support



866
Chest, head and
back support



heel-supports

adjustable in width and
backwards-forwards



knee-pads

adjustable in height,
width and
backwards-forwards



standard lifting band

ergonomic, with
anti-slip lining
fabric. Hooks to
allow traction while
climbing.
An **alternative
maxi size** is
available (**907
model**: please see
measures on the
rear page)



lifting band with pelvis belt

**Alternative 908
lifting band with
pelvis belt.**
A **maxi size** is
available (**909
model**: please see
measures on the
rear page)

functions

table it is adjustable in height



table it is adjustable in backwards-forwards



table it is adjustable in tilt (0°-23°)

