

OBI

INGLESE Cod. 22071 21/09/10



CRASH TESTED for the forward-facing transport of the pushchair in a motor vehicle (private vans/cars, buses..)

CRASH TESTED
ACCORDING TO THE
ISO 7176/19

The copyright even if partial is forbidden without any authorization of the manufacturer. The manufacturer reserves the right to introduce any changes without prior notice.

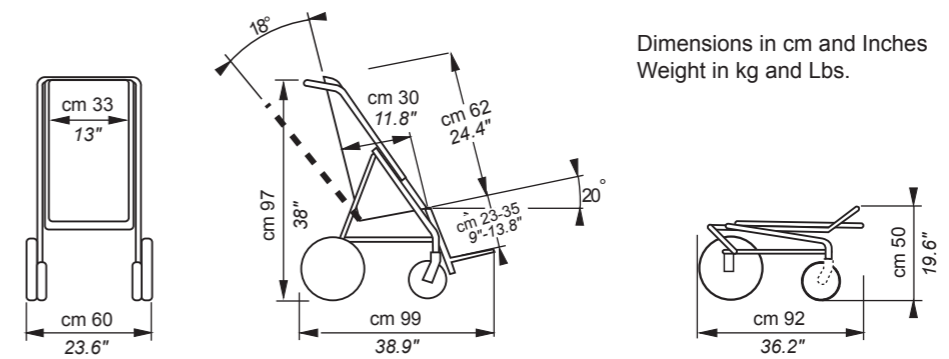

OBI 2 Weight of the aid kg 17,4 (Lbs. 38.3) Max load kg 50 (Lbs. 110)

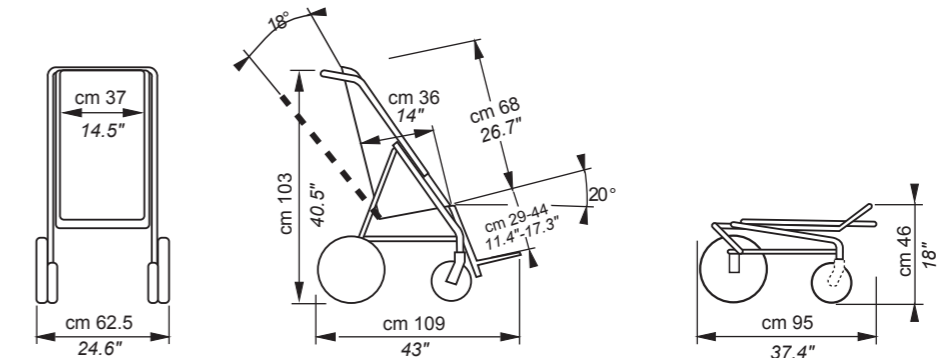

OBI 3 Weight of the aid kg 18,5 (Lbs. 40.7) Max load kg 60 (Lbs. 132)

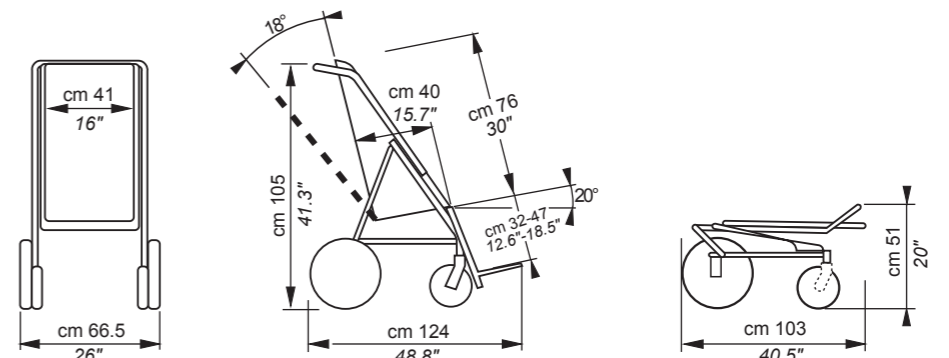

OBI 4 Weight of the aid kg 20,1 (Lbs. 44.2) Max load kg 70 (Lbs. 154)

THE NUMBERS DIVIDED BY THE DASH SPECIFY A MINIMUM AND A MAXIMUM ADJUSTMENT

PRODUCT MARKED **CE**

Product Certified by the
Following Institute
CERAH France



CRASH TESTED
according to the ISO 7176/19

Authorized Dealer

design and quality
MADE IN ITALY since 1980

ORMESA®

ORMESA® s.r.l.

Via A. Da Sangallo,1 06034 FOLIGNO (PG) ITALY
TEL. +39 0742 22927 - FAX +39 0742 22637
info@ormesa.com - www.ormesa.com

technical features

- Steel and aluminium **folding frame**, painted with non-toxic epoxy varnish
- **Trevira, padded, fire-retardant and removable upholstery**, machine washable at 30°
- **Chassis** made of natural-looking "cordura du pont" nylon, hard-wearing, washable



- 1 - slots for headrest**
- 2 - slots for harness (853)**
- 3 - side protections** on the frame
- 4 - 828 chest belt** (accessory)
- 5 - slots for abduction block**
- 6 - quick release adjustment** for the footrest
- 7 - adjustable tip-up footrest**
- 8/9 - wheels**, sliding on ball bearings:
front 17,5-cm. (7") swivel, unpierceable
rear pneumatic 30-cm. (12") unpierceable rubber on request
- 10 - independent brake**, light to use but hard wearing.
No dangerous protuberances
- 11 - fold lock**



Rigid backrest with four quick release recline positions.
Rigid fixed seat.
Quick release **reclinable legrest**

accessories



834 Abduction block



835 Headrest with two side elements, which can be used one at a time (either the left side or the right side)



853 Adjustable harness



812 Wheel direction locks



817 Inguinal straps



816 Side supports



827 Foot straps



839 Front handle



894 45° Belt for the pelvis



858 Basket

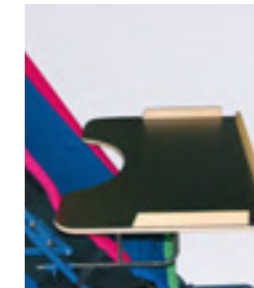

824 Table with edge and hollow



837 Tray



819 Canopy



825 Rain cover (the rain cover can only be attached after the canopy 819)



818 Thermic cover



832 Optional frame for narrow passages and lifts (the external width is reduced by 7 cm (3"). Light undetachable wheels with solid tyres; 20 cm (8") rear wheels, 17 cm (7") front wheels, on all bearings.



891 Set of 4 tie down hooks for the forward-facing transport of the pushchair in a motor vehicle (private vans/cars, buses..)

WARNINGS:

- fits the ISO 10542 compliant 4-POINT STRAP-TYPE TIEDOWN, provided by the vehicle
- it is required for the child to wear both pelvic- and shoulder-belt-type restraints, to be compliant either with ISO 7176-19 or ISO 10542. Postural belts and harnesses such as our 828, 853 and 894 are not approved for the use as an occupant restraint system, but they can be used in addition
- the vehicle must be suitable for transporting orthopedic pushchairs in compliance with current law
- read the warnings and instructions given in the user's & maintenance book



833 Base with 12" wheels