

NOVUS

CRASH TESTED for the forward-facing transport of the pushchair in a motor vehicle (private vans/cars, buses..)



CRASH TESTED
Novus passed CRASH TEST according to the ANSI RESNA WC19

INGLESE cod. 2220-06-04-10

The copyright even if partial is not allowed without the authorization of the manufacturer. The manufacturer reserves the right to make changes without any notice

The Novus is available in three sizes

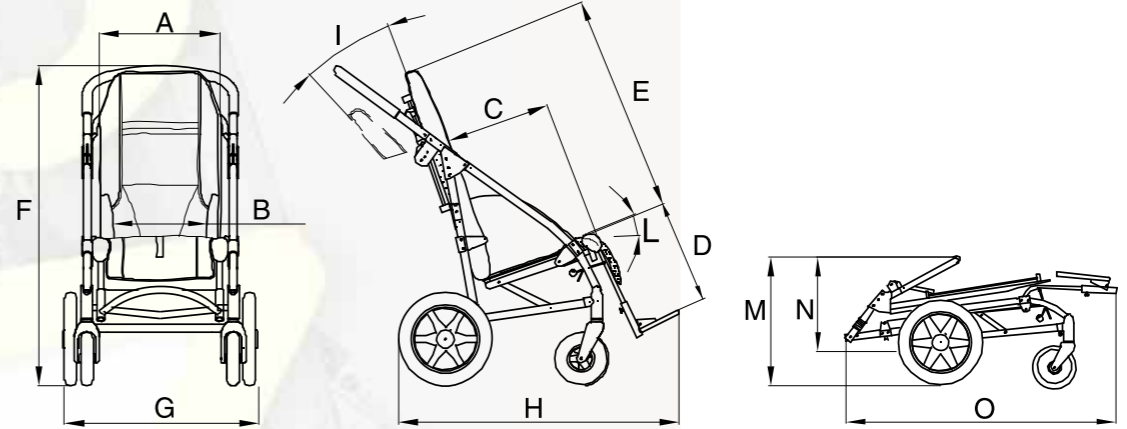

Sizes	Max. User Mass	A	B	C	D	E	F	G	H	I	L	M	N	O	Weight of the aid	Weight of the aid without wheels
2	kg. 45	cm. 40	cm. 20-30	cm. 30-36	cm. 27-37	cm. 65-71	cm. 103	cm. 60	cm. 87	20°	20°	cm. 52	cm. 38	cm. 85	Kg. 19.5	Kg. 15.9
3	kg. 55	cm. 43	cm. 24-34	cm. 35-41	cm. 29-41	cm. 67-73	cm. 103	cm. 63	cm. 93	20°	20°	cm. 53.5	cm. 39	cm. 91	kg. 20.6	kg. 17
4	kg. 65	cm. 46	cm. 28-38	cm. 39-45	cm. 35-45	cm. 72-78	cm. 107	cm. 66	cm. 96	20°	20°	cm. 55	cm. 40	cm. 99	kg. 21.6	kg. 18

HYPHEN SEPARATED NUMBERS INDICATE A MINIMUM AND MAXIMUM RANGE OF ADJUSTMENT



Novus passed CRASH TEST according to the ANSI RESNA WC/19

CE

PRODUCT TESTED BY

TÜV BERLIN

design and quality
MADE IN ITALY since 1980

ORMESA

ORMESA

s.r.l. - Via A. Da Sangallo, 1 - PACIANA
06034 FOLIGNO (PG) ITALY - TEL. +39 0742 22927 (r.a.) FAX +39 0742 22637
info@ormesa.com - www.ormesa.com



COMPANY WITH QUALITY MANAGEMENT
SYSTEM CERTIFIED BY DNV
= ISO 9001:2008 =

Technical features and functions

NOVUS

accessories

Customize the pushchair with a complete range of accessories!



812 WHEEL DIRECTION LOCKS



858 MESH BASKET



818 THERMAL COVER



819 CANOPY



825 RAIN COVER to be fixed to the 819 canopy



827 FOOTSTRAPS



834 ABDUCTION BLOCK



838 PADDED SIDE SUPPORTS



839 FRONT HANDLE



817 INGUINAL STRAPS



852 HEADREST with Parietal Supports. It is adjustable in height and width



863 HEADREST with Occipital-parietal Supports. It is adjustable in height, in width, in tilt, forwards and backwards



824 TRAY



844 SIDE PROTECTING COVERS



868 SIDE WRAPPABLE and FLEXIBLE SUPPORTS for the trunk. Height and width adjustable



903 FIVE POINT VEST HARNESS



906 FIVE POINT HARNESS



853 VEST HARNESS



828 CHEST BELT



894 45° BELT FOR THE PELVIS



891 SET OF 4 TIE DOWN HOOKS for the forward-facing transport of the pushchair in a motor vehicle (private vans/cars, buses..)

- **Aluminium FOLDABLE FRAME** (fig.1) painted with non-toxic epoxy powders
- **Padded, ergonomic and removable UPHOLSTERY.** It is fixed to the seat thanks to press-studs. It is covered with highly breathable, wear and tear resistant fabric; fire-retardant according to the UNI 9177 and to the EN 1021-1/2 standards. It was designed to make the change of position of the side supports easier, and to fix or unfix the accessories without causing any trouble to the child while he is seated. It grows up with the frame
- **SEAT**, adjustable in width and depth
- **RIGID BACKREST**, adjustable in height and in tilt
- **REMOVABLE WHEELS** snap-off (fig. 2), sliding on ball bearings:
 - front 17,5-cm. (7"), swivel, puncture-proof
 - rear 30-cm. (12"), pneumatic. Puncture-proof rubber or request
- **INDEPENDENT DRUM BRAKES**, without any dangerous projections



(fig.1)



(fig.2)

WARNING:

- fits the ISO 10542 or SAE J2249 compliant 4-POINT STRAP-TYPE TIEDOWN, provided by the vehicle
- it is required for the child to wear both pelvic- and shoulder-belt-type restraints, to be compliant either with ANSI RESNA WC/19 or ISO 7176-19
- postural belts and harnesses such as our 828, 853, 868, 894, 903, 906 are not approved for the use as an occupant restraint system
- the vehicle must be suitable for transporting orthopedic pushchairs in compliance with current law
- read the warnings and instructions given in the user's & maintenance book