

MINI STANDY



INGLESE - COD. 22061-1/12/09

®
O
R
M
E
S
A



Authorized Dealer

CE

PRODUCT TESTED BY
TÜV BERLIN

COMPANY
WITH QUALITY MANAGEMENT
SYSTEM CERTIFIED BY DNV
= ISO 9001:2000 =

 design and quality
MADE IN ITALY since 1980

O R M E S A ®

 s.r.l.

Via A. Da Sangallo, 1 06034 FOLIGNO (PG) ITALY
TEL. +39 0742 22927 - FAX +39 0742 22637
info@ormesa.com - www.ormesa.com

The copyright even if partial is not allowed
without the authorization of the manufacturer
The manufacturer reserves the right to make
changes without any notice

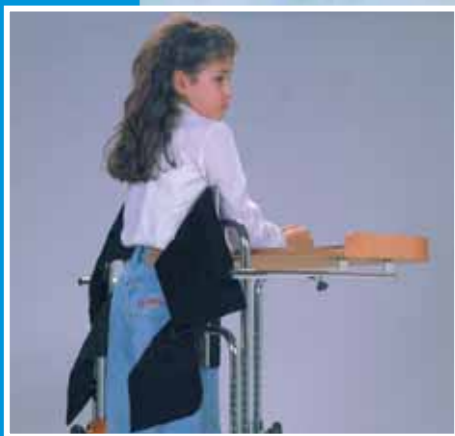

ADJUSTABLE SUPPORT with velcro strip



Adjustable **KNEE PADS** for **FOOT FLEXION-EXTENSION**



Adjustment of **ADDUCTION-ABDUCTION OF LEGS**



Removable **WORK TABLE**, IT IS **ADJUSTABLE** in height and depth



Adjustable **FRONT** and **BACK CHEST SUPPORT**



Adjustable **FRONT** and **BACK PELVIC SUPPORT**

FRAME with a **SMOOTH CONTOUR** to **ALLOW TRUNK ROTATION** and **SIDWAYS ARM MOVEMENT**.



If the child has **SUFFICIENT TRUNK CONTROL**, only the **PELVIC SUPPORT BAND** is necessary

DIMENSIONS in cm.

MINI STANDY 2

Weight 19,9 kg
Max cap load 45 kg

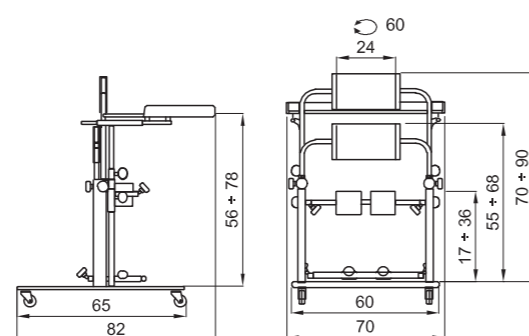

MINI STANDY 3

Weight 23,9 kg
Max cap load 55 kg

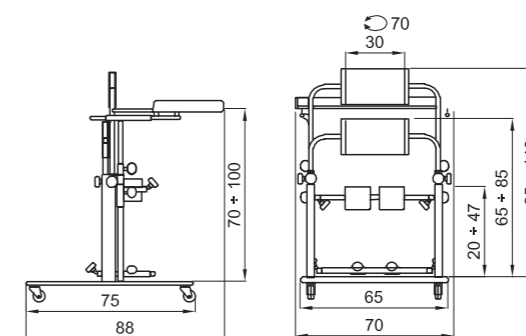

The manufacturer reserves the right to make any changes without prior notice.

Reproduction even if partial is forbidden without any authorization of the manufacturer.