

CLIP

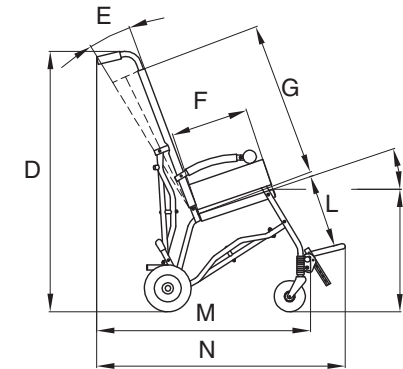

INGLESE Cod. 22429/A 03.12.2010

measures in centimeters, weights in kilos

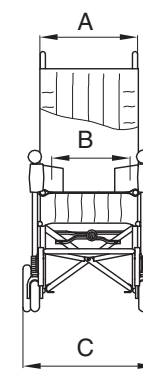

CLIP 1-2-3

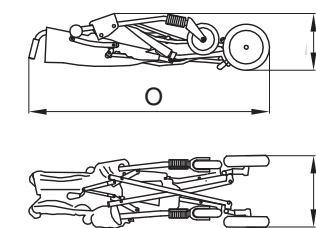

THE NUMBERS DIVIDED BY THE DASH SPECIFY A MINIMUM AND A MAXIMUM ADJUSTMENT

	MAX. USER MASS	A	B	C	D	E	F	G	H	I	K	L	M	N	O	P	Q	WEIGHT OF THE AID
CLIP 1	30 kg	40 cm	30 cm	51 cm	99 cm	0°-12°	25 cm	55 cm	18°	46 cm	--	15-23 cm	73 cm	80 cm	110 cm	30 cm	32 cm	10,8 kg
CLIP 2	35 kg	40 cm	33 cm	51 cm	99 cm	0°-12°	30 cm	59 cm	18°	48 cm	--	21-31 cm	73 cm	90 cm	110 cm	30 cm	32 cm	11 kg
CLIP 3	40 kg	40 cm	36 cm	51 cm	104 cm	0°-12°	35 cm	64 cm	18°	49 cm	--	27-37 cm	79 cm	96 cm	115 cm	32 cm	35 cm	11,2 kg
CLIP 4	76 kg	45 cm	*33 cm	57 cm	112 cm	0°-10°	38 cm	70 cm	18°	59 cm	95 cm	36-48 cm	82 cm	105 cm	115 cm	56 cm	34 cm	12,5 kg

* Seat width is cm 45 if you remove the lateral paddings

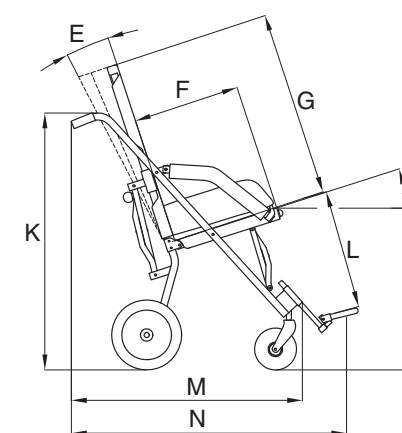
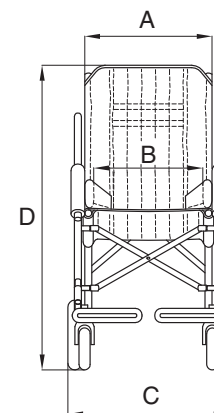

CLIP 4

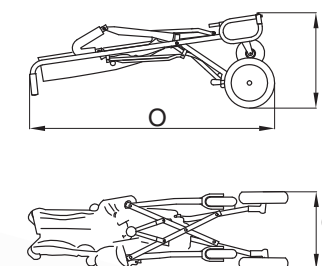

COMPANY WITH QUALITY MANAGEMENT
SYSTEM CERTIFIED BY DNV
= ISO 9001:2008 =

Product Certified by the
Following Institute
CERAH France



Clip passed the CRASH TEST according to the ISO 7176-19 for the forward-facing transport of the pushchair in a motor vehicle (private vans/cars, buses..)

design and quality
MADE IN ITALY since 1980

ORMESA

ORMESA

S.r.l. Via A. Da Sangallo, 1 - Loc. PACIANA - 06034 FOLIGNO (Pg) ITALY
Tel.: +39 0742 22927 (r.a.) Fax: +39 0742 22637 E-mail: info@ormesa.com http://www.ormesa.com

Functions

Pre-Engineered for **headrest**

Pre-Engineered for **vest harness**

Pre-Engineered for **side trunk supports**

Semirigid seat with inner aluminium supports

8" (20 cm) **solid wheels** with brakes



3 Seatback positions available through the ingenious use of zippers (pict. 1). Seatback and seat have aluminium bars for rigidity contouring

Breathable upholstery

Frame lock

Legrest strap

6" (15 cm) **castor wheels**



Net basket on the back of the backrest (pict.1)

Footrest: detachable and height adjustable

CLIP 1-2-3

The CLIP is **light weighted** and can be **easily folded**

The CLIP has an **inclined seat** to assure the **maximum comfort** to the child.



Folding aluminium frame



CLIP 4

Accessories



▶ **812**
Directional locks



▶ **827**
Foot straps



▶ **817**
Leg straps for abduction



▲ **828**
Seat belt



▲ **894**
Pelvic belt



▲ **819**
Canopy



▲ **818**
Thermal cover



▲ **825**
Rain cover
to be fixed to the 819 canopy



▶ **816**
Side supports for the trunk



▶ **835**
adjustable Headrest



▶ **853**
Vest harness



▶ **906**
Five point harness



▶ **903**
Five point vest harness

WARNING:
- fits the ISO 10542 compliant 4-POINT STRAP-TYPE TIEDOWN, provided by the vehicle
- it is required for the child to wear both pelvic- and shoulder-belt-type restraints, to be compliant either with ISO 7176-19 or ISO 10542
- postural belts and harnesses such as our 828, 853, 894, 903, 906 are not approved for the use as an occupant restraint system
- the vehicle must be suitable for transporting orthopedic pushchairs in compliance with current law
- read the warnings and instructions given in the user's & maintenance book



▶ **891 SET OF 4 TIE DOWN HOOKS** for the forward-facing transport of the pushchair in a motor vehicle (private vans/cars, buses..)

